

Installation Instructions

Tools Needed

- Screw Gun*
- Box End Wrench, 1/2" Drive Impact Wrench, or Ratchet
- Electric reciprocating saw to cut ColorGard cross-member
- Tin Snips
- String Line
- Torque Wrench
- Pliers or Vice Grip Pliers.

Instructions

- 1. Before you start:** First, use a string line across the top of the panel seams at the desired location to establish a true line for installation of the S-5! clamps. Individually measuring from the eave to determine each clamp location is not recommended **(1)**.
- 2. Preparing the Clamps:** If the ColorGard assembly utilizes the VersaClip™ for attachment of the ColorGard cross-member, the bolt hole in the clamp should be at the upslope end of the clamp. If the assembly uses punched ColorGard without VersaClip, the hole should be at the downslope end of the clamp. When using the S-5-U, determine which side of the clamp to load the setscrews into, and thread the setscrews into all clamps, being careful that the bolt hole will be in the correct (upslope or downslope) orientation, with the setscrews on the correct side of the seam. Both setscrews must be on the same side of the clamp **(2)**.
- 3. Installing the clamps:** S-5! clamps are installed differently depending upon clamp model and seam style. Please see the installation instructions included with your clamps. For maximum holding strength, setscrews should be tensioned and re-tensioned as the seam material compresses. Screw tension should be verified using a calibrated torque wrench between 160 and 180 inch pounds when used on 22ga steel and between 130 and 150 inch pounds for all other metals and thinner gauges of steel.

Using VersaClip™: When seam spacing is not divisible by 4", when panels are not laid up true-to-dimension, or when ColorGard is installed askew to the panel seams **(3)** (e.g. parallel with the line of a valley), the VersaClip facilitates installation. The VersaClips are inserted into the ColorGard prior to placement of ColorGard on the clamps. Align clips with S-5! clamp. VersaClip can be used with punched or unpunched ColorGard.

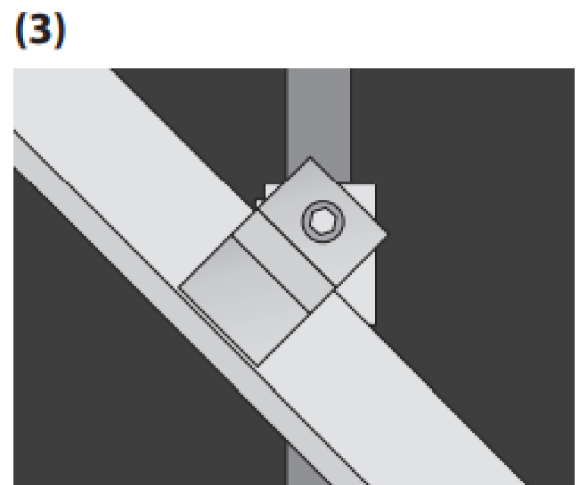
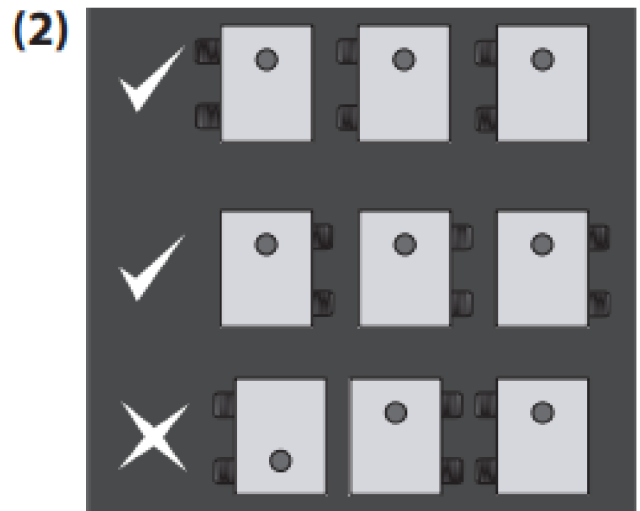
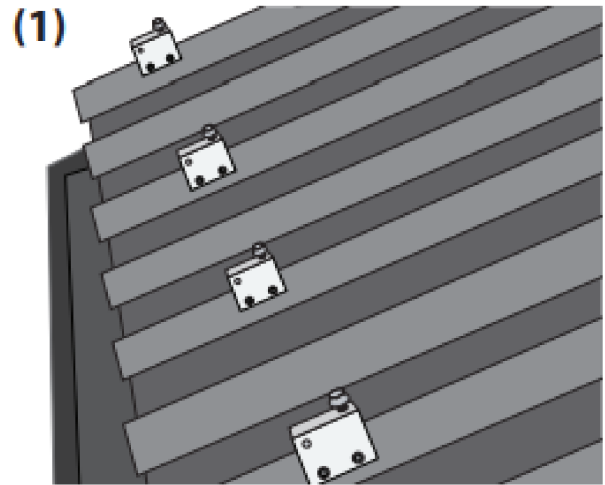

Installation Instructions

4. **Installing the ColorGard:** To maintain color conformity over time, ColorStrips should be sheared from the same prefinished metal as the roof panels (supplied by others). Shear strips to exactly 2" wide (8' or 10' long). Slide the ColorStrip into the ColorGard cross-member as shown **(4a)**. If the strip length is 8', it may be pre-assembled into the ColorGard cross-member. If the strip is 10' long, it will be assembled to the ColorGard as installation progresses. Joints in the ColorGard should be concealed by offsetting the joints of the ColorStrip from the joints of the ColorGard. The joints of the ColorStrips can be overlapped about 1/2" if desired. Each ColorStrip should be secured to the ColorGard somewhere along its length. This is done by pinching the retainer lip of the ColorGard with an ordinary pair of pliers **(4b)**. It can be done at one end of the ColorGard section or anywhere along its length to prevent lateral migration of the ColorStrip.

5. **Bolt ColorGard® to clamps:** **(5a)** Attach ColorGard to clamps with the stainless bolts provided. Bolts can be tightened with a 1/2" (13mm) box-end wrench, or ratchet **(5a)**. On larger jobs, a 1/2" drive electric impact will expedite this work. Tension bolts to a minimum of 13 ft-lbs. (18 Nm). Add splice pieces at each ColorGard joint as shown below **(5b)**. The "dimple" in the splice piece will automatically provide a 3/8" space between adjoining sections **(5c)** to allow for linear thermal expansion of the ColorGard. Trim ColorGard at the end of the assembly, being sure it does not cantilever more than 8" beyond the last clamp of an assembly. Any trimmed piece of ColorGard must be attached with at least two clamps.

ColorGard® Cutting Tip: If it is necessary to field cut ColorGard, such as at the end of an assembly, it can be done with a hack saw or electric reciprocating saw with a fine tooth metal cutting blade. A power mitre saw with a fine tooth carbide tip blade also works well.

(4a)

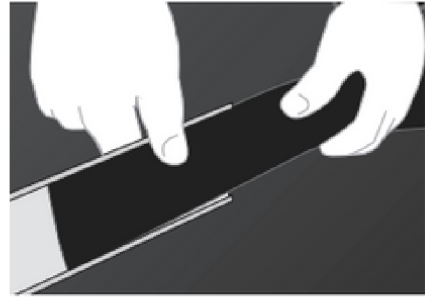

(4b)

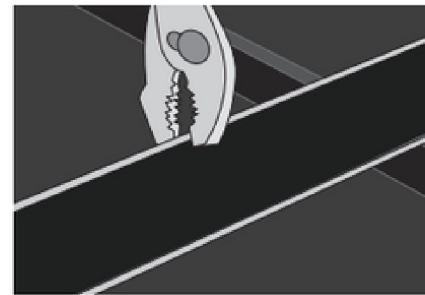

(5a)

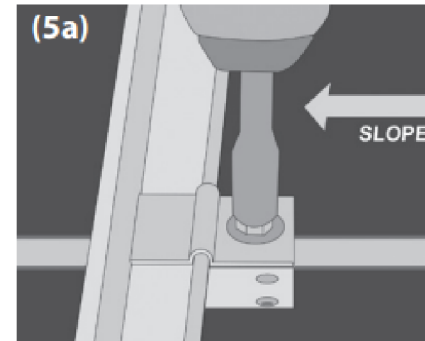

(5b)



(5c)

